



MANUFACTURER OF QUALITY AIR TOOLS & COMPONENTS

2005
CATALOG



CONTENTS

New Tools	1
Grinders	
Die	2
Extended Die	3
Extended Wheel	4
Right Angle Wheel	5-6
Right Angle Collet	7
Extended Right Angle Wheel	8
Extended Right Angle Collet	9
Router & Cut-Off Wheel Tool	10
Air Marking Pens	11
Scalers	12-14
Riveting Hammers	14
Riveting Hammers & Weld Flux Chisels	15
Sanders	
Angle and Extended Angle	16
Warranty & Terms	Inside Back Cover

Rear Exhaust Grinder

Everything you have come to expect from a *PATCO* grinder is now available in a rear exhaust design!

The **RE-3175K** comes standard with the overhose assembly that provides excellent noise reduction as well as carrying the exhaust away from the work surface and operator.



New from *Patco!*

RE-3175K

G-3175K

- Rugged 1hp motor
- 23,000 rpm
- Steel or aluminum motor housing
- Double angle collet for extreme accuracy
- 12" overhose assembly and 18" whip hose ¼" NPT

STANDARD EQUIPMENT RE-3175K

- G-3327 Wrench
- G-3858 Wrench
- G-3729 1/4" collet

Patco Model No.	RPM	Throttle Type	Spindle thread	Collet size	Overall length	Net Weight	Housing Type	Air Inlet
RE-3175K	23,000	Self closing lever	3/8 - 24 x 9/16	¼"	6 ½"	3 lbs.	Steel	¼" NPT
RE-3175AK	23,000	Self closing lever	3/8 - 24 x 9/16	¼"	6 ½"	2 lbs.	Aluminum	¼" NPT



APPLICATIONS

These tools are very popular, all-purpose die grinders for applications such as deburring, die contouring, flash and removal, blending and smoothing. They are primarily used with carbide burrs and mounted points. Industries using the grinders include: metal fab shops, die shops, foundries, steel mills, shipyards and construction.

G-3507 SERIES

- Rugged 1/3 hp motor, 35,000 rpm
- Compact, lightweight, easy to handle
- Steel motor housing-withstands rugged use
- Shown is optional lock-off lever throttle which prevents accidental start-up of the tool
- Interchangeable with CP-9107



G-3507

G-1340 SERIES

- Rugged 1 hp motor
- 25,000 or 18,000 rpm
- Steel motor housing to withstand heavy use
- Double angle collet for extreme accuracy
- Motor parts interchangeable with other 1340/1350 tools
- Interchangeable with CP-9113



G-1340

G-1340A SERIES

- Lightweight aluminum body for over-head work or where a lighter tool is needed
- Motor parts interchangeable with other 1340/1350 tools
- Interchangeable with CP-9113



G-1340A

G-1350 SERIES

- Rugged 1 hp motor
- 25,000 or 18,000 rpm
- Steel motor housing to withstand heavy use
- Safety lever
- Motor parts interchangeable with other 1340/1350 tools
- Interchangeable with CP-9113G



G-1350

STANDARD EQUIPMENT

(G1340 & G1350 Series only)

- G-3327 Wrench
- G-3858 Wrench
- G-3729 1/4" Collet

OPTIONAL EQUIPMENT

- Various Collet sizes (see Accessories)
- Safety Lever G-3781 on -1340 style housing

Now available in lightweight aluminum

Patco Model No.	RPM	Throttle Type	Spindle Thread	Collet Size	Overall Length	Net Weight	Housing Type	Air Inlet
G3507	35,000	Lever Self Closing	5/16 - 24 x 1/2	1/4"	5"	1 lb.	Steel	1/4 NPT
G-1340 G-1340-18	25,000 18,000	Lever Self Closing	3/8 - 24 x 9/16	1/4"	6 1/4"	2 lbs. 4 oz.	Steel	1/4 NPT
G-1340A G-1340A-18	25,000 18,000	Lever Self Closing	3/8 - 24 x 9/16	1/4"	6 1/4"	1 lb. 9 oz.	Aluminum	1/4 NPT
G-1350 G-1350-18	25,000 18,000	Safety Lock Off	3/8 - 24 x 9/16	1/4"	6 1/4"	2 lbs. 8 oz.	Steel	1/4 NPT

APPLICATIONS

These grinders are used with mounted points and carbide burrs for a variety of applications such as die construction and repair, weld cleaning, casting and forging clean-up, deburring, blending and smoothing. User industries include die shops, foundries, maintenance areas and fabrication shops.

GE-1340-C SERIES

- Ideal for work in deep crevices or other recessed areas
- Double angle collet allows for exceptional accuracy
- Adjustable side exhaust deflector
- Heavy duty steel housing
- Rugged 1 hp motor
- Motor parts interchangeable with 1340/1350 tools
- Interchangeable with CP-9113ES

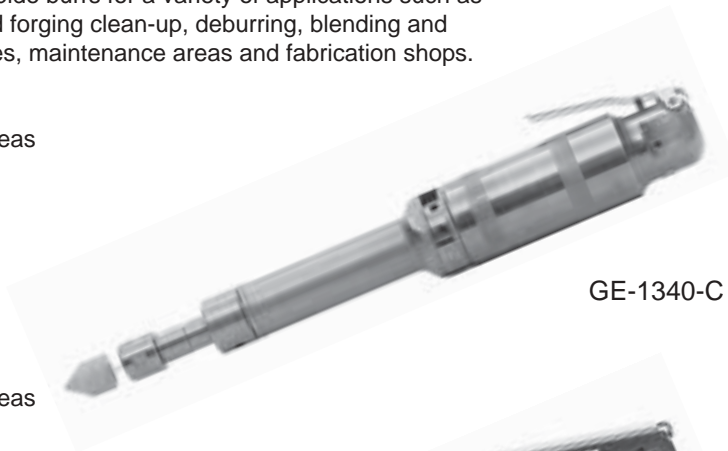

GE-1340-C

GE-1350-C SERIES

- Ideal for work in deep crevices or other recessed areas
- Double angle collet allows for exceptional accuracy
- Adjustable side exhaust deflector
- Heavy duty steel housing
- Safety lever
- Rugged 1 hp motor
- Motor parts interchangeable with 1340/1350 tools
- Interchangeable with CP-9113GES



GE-1350-C

Now available in lightweight aluminum

GE1340A-C SERIES

- Ideal for work in deep crevices or other recessed areas
- Double angle collet allows for exceptional accuracy
- Adjustable side exhaust deflector
- Lightweight aluminum housing
- Rugged 1 hp motor
- Motor parts interchangeable with 1340/1350 tools
- Interchangeable with CP-9113ES

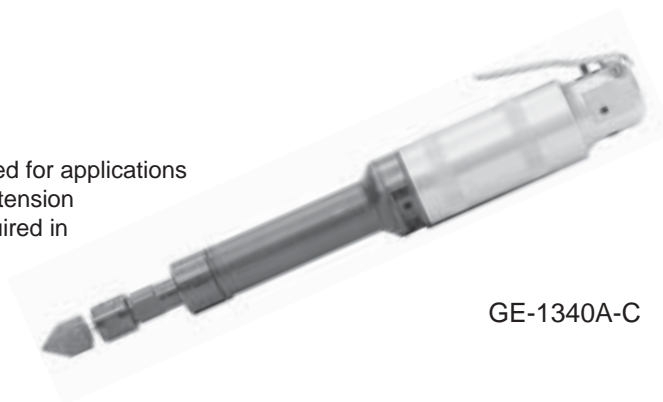

GE-1340A-C

GE- HEAVY DUTY SERIES

Our extra heavy-duty extended die grinder has been developed for applications where other extended grinders have failed to perform. The extension assembly is designed to handle high side load pressures required in many hard to reach areas.

- Heavy-duty 1 hp motor
- Available in steel or aluminum housing
- Side exhaust with adjustable deflector
- Interchangeable motor parts with all 1340 and 1350 series grinders

(When ordering the GE- Heavy Duty Series extended die grinders, indicate -HD after the standard extended grinder style, i.e. GE-1340-C-HD)

STANDARD EQUIPMENT

- G-3729 1/4" collet
- G-3327 Wrench
- G-3858 Wrench

OPTIONAL EQUIPMENT

- Various collet sizes (see Accessories)
- G-3781 Safety Lever on -1340 style housing

Patco Model No.	RPM	Throttle Type	Spindle Thread	Collet Size	Overall Length	Net Weight	Housing Type	Air Inlet
GE-1340-C	25,000	Lever Self Closing	3/8 x 24	1/4"	11 1/8"	3 lbs. 5 oz.	Steel	1/4 NPT
GE-1350-C	25,000	Safety Lock Off	3/8 x 24	1/4"	11 1/8"	3 lbs. 9 oz.	Steel	1/4 NPT
GE-1340A-C	25,000	Lever Self Closing	3/8 x 24	1/4"	11 1/8"	2 lbs. 10 oz.	Aluminum	1/4 NPT

Heavy-Duty Extended Grinder

GE-1340-C-HD	25,000	Lever Self Closing	3/8 x 24	1/4"	11 1/8"	3 lbs. 8 oz.	Steel	1/4 NPT
GE-1340AC-HD	25,000	Lever Self Closing	3/8 x 24	1/4"	11 1/8"	2 lbs. 13 oz.	Aluminum	1/4 NPT
GE-1350-C-HD	25,000	Safety Lock Off	3/8 x 24	1/4"	11 1/8"	3 lbs. 12 oz.	Steel	1/4 NPT
GE-1350AC-HD	25,000	Safety Lock Off	3/8 x 24	1/4"	11 1/8"	3 lbs.	Aluminum	1/4 NPT



EXTENDED WHEEL GRINDERS

APPLICATIONS

These grinders are used for weld smoothing, casting cleanup, and burr removal in fabrication shops, die shops, shipyards, power plants, refineries and many other industries.

GE- CONE & PLUG WHEEL GRINDERS

Designed for hard-to-reach surfaces in die construction, castings and forgings. Also excellent when an extended reach is needed for weld cleaning, deburring, blending and smoothing.

- Heavy-duty 1 hp motor
- Available in steel or aluminum housing
- Interchangeable motor parts with all 1340/1350 series tools



GE-1340-20

GE-1340-W SERIES

- Heavy duty 1 hp motor
- Extended housing for better reach and control
- Solid steel motor housing ensures longevity
- Interchangeable wheel guards-3" and 4"
- Side exhaust system directs exhaust away from work area
- 18,000 rpm
- Motor parts interchangeable with 1340/1350 tools
- Interchangeable with CP-3040-LANHUT



GE-1340-W

GE-1350-W SERIES

- Heavy duty 1 hp motor
- Extended housing for better reach and control
- Solid steel motor housing ensures longevity
- Interchangeable wheel guards-3" and 4"
- Side exhaust system directs exhaust away from work area
- 18,000 rpm
- Safety lever
- Motor parts interchangeable with 1340/1350 tools
- Interchangeable with CP-3040-GANHUT



GE-1350-W

Now available in lightweight aluminum

GE-1340A-W SERIES

- Heavy duty 1 hp motor
- Extended housing for better reach and control
- Lightweight aluminum body
- Interchangeable wheel guards-3" and 4"
- Side exhaust system directs exhaust away from work area
- 18,000 rpm
- Motor parts interchangeable with 1340/1350 tools
- Interchangeable with CP-3040-LANHUT



GE-1340A-W

STANDARD EQUIPMENT

- GE-3939 3" wheel guard
- G-3858 Wrench
- G-3327 Wrench

OPTIONAL EQUIPMENT

- GE-3781 Safety Lever on G-1340 style housing
- GE-3764 4" Wheel Guard

Patco Model No.	RPM	Throttle Type	Spindle Thread	Wheel Capacity	Overall Length	Net Weight	Housing Type	Air Inlet
GE-1340-W	18,000	Lever Self Closing	3/8 x 24	3"	12 1/2"	3 lbs. 12 oz.	Steel	1/4 NPT
GE-1350-W	18,000	Safety Lock Off	3/8 x 24	3"	13 1/2"	4 lbs.	Steel	1/4 NPT
GE-1340A-W	18,000	Lever Self Closing	3/8 x 24	3"	13 1/2"	3 lbs. 1 oz.	Aluminum	1/4 NPT

Use only reinforced Type 1 wheels. 3" dia x 1/2" max width x 3/8" center hole; wheels not included. Available in 4" wheel capacity model. When ordering specify 4" wheel with -4, (i.e. GE-1340-4). The -4 model uses only reinforced Type 1 wheels 4" dia. x 1/4" max width x 3/8" center hole; wheels not included.

CONE & PLUG WHEEL GRINDERS

GE-1340-20	20,000	Lever Self Closing	3/8 x 24	Cone & Plug	11"	3 lbs. 4 oz.	Steel	1/4 NPT
GE-1340A-20	20,000	Lever Self Closing	3/8 x 24	Cone & Plug	11"	2 lbs. 8 oz.	Aluminum	1/4 NPT
GE-1350-20	20,000	Safety Lock Off	3/8 x 24	Cone & Plug	11"	3 lbs. 8 oz.	Steel	1/4 NPT
GE-1350A-20	20,000	Safety Lock Off	3/8 x 24	Cone & Plug	11"	2 lbs. 12 oz.	Aluminum	1/4 NPT

RIGHT ANGLE WHEEL GRINDERS



GA-RIGHT ANGLE SERIES TYPE 27 AND TYPE 1 WHEEL GRINDERS

The very popular GA-1340 and GA-1350 style Type 27 wheel tool is now also available in a Type 1 wheel design. The spindle has been lengthened to allow a Type 1 wheel with a maximum width of 1/4". For those tight spaces, when cutting or edge grinding is required, the GA- Series Type 1 wheel grinders can meet the challenge. Industrial applications include foundries, welding shops, fabrication plants, steel mills and shipyards.

- Heavy duty 1 hp motor
- 15,500 free speed RPM
- Spiral bevel gears
- Available in steel or aluminum housing
- Side exhaust with adjustable deflector
- Small head for easy accessibility to tight work surfaces
- Interchangeable motor parts with all 1340 and 1350 series grinders

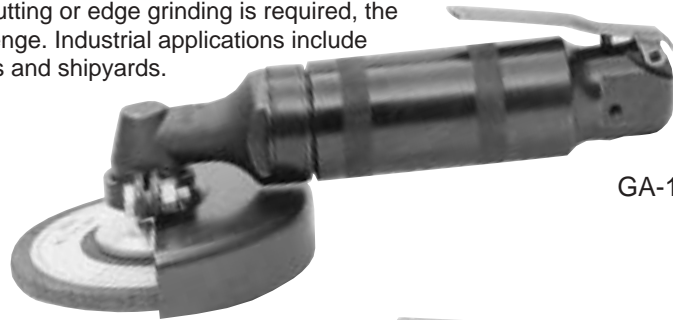

GA-1340

GA-1340 SERIES

- Interchangeable with CP-3040-LABTIM

GA-1350 SERIES

- Safety Lever
- Interchangeable with CP-3040-GABTIM



GA-1350

Now available in lightweight aluminum

GA1340A SERIES

- Interchangeable with CP-3040-LABTIM



GA-1340A

STANDARD EQUIPMENT

TYPE 1

- GA-3500 4" Wheel Guard
- GA-3495-1 Wheel Spindle Nut
- GA-3588-1 Wheel Nut
- GA-3652 Spanner Wrench
- GA-3653 Wrench
- G-3858 Wrench

STANDARD EQUIPMENT

TYPE 27

- GA-3500 4" Wheel Guard
- GA-3495 Wheel Adapter
- GA-3588 Wheel Nut
- GA-3652 Spanner Wrench
- GA-3653 Wrench
- G-3858 Wrench

Patco Model No.	RPM	Throttle Type	Spindle Thread	Collet Size	Overall Length	Net Weight	Housing Type	Air Inlet
GA-1340	13,500	Lever Self Closing	3/8 - 24	3" and 4" Type 27	8"	3 lbs. 2 oz.	Steel	1/4 NPT
GA-1350	13,500	Safety Lock Off	3/8 - 24	3" and 4" Type 27	8"	3 lbs. 6 oz.	Steel	1/4 NPT
GA-1340A	13,500	Lever Self Closing	3/8 - 24	3" and 4" Type 27	8"	2 lbs. 7 oz.	Aluminum	1/4 NPT

Use only reinforced Type 27 wheels; 3" or 4" dia. x 1/4" width max x 3/8" center hole; wheels not included.

OPTIONAL EQUIPMENT

- GA-3480 3" Guard
- G-3781 Safety Lever on -1340 style housing

Type 1 Wheel Right Angle Grinder

GA-1340-1	15,500	Lever Self Closing	3/8 - 24 1" Long	3" & 4" Type 1	8"	3 lbs. 2 oz.	Steel	1/4 NPT
GA-1340A-1	15,500	Lever Self Closing	3/8 - 24 1" Long	3" & 4" Type 1	8"	2 lbs. 7 oz.	Aluminum	1/4 NPT
GA-1350-1	15,500	Safety Lock Off	3/8 - 24 1" Long	3" & 4" Type 1	8"	3 lbs. 6 oz.	Steel	1/4 NPT
GA-1350A-1	15,500	Safety Lock Off	3/8 - 24 1" Long	3" & 4" Type 1	8"	3 lbs. 4 oz.	Aluminum	1/4 NPT

IMPORTANT: Grinding wheel RPM must exceed tool RPM rating. Never mount bonded grinding wheels. Always wear eye, face and body protection. Use only reinforced Type 1 wheels, 3" & 4" dia. x 1/4" wide max. x 3/8" center hole; wheels not included.



RIGHT ANGLE WHEEL GRINDERS

The GA-11 Series tools are *PATCO*'s most durable right angle grinder. Designed for applications that other grinders cannot handle, spiral beveled gears and a wick-type lubricating system delivers the durability you need in the most challenging of conditions. This grinder is available in a 4" - 5" Type 27 wheel, used for grinding, deburring and blending. Industrial applications include foundries, welding shops, fabrication plants, steel mills and shipyards.

GA-11 SERIES

- Heavy Duty 1 hp motor
- 11,000 free speed RPM
- Spiral bevel gears
- Available in steel or aluminum housing
- Side exhaust with adjustable deflector
- Dead handle for added stability and leverage
- Interchangeable motor parts with all 1340 and 1350 series grinders



GA-11650
-1350 housing shown

Patco Model No.	RPM	Throttle Type	Spindle Thread	Wheel Capacity	Overall Length	Net Weight	Housing Type	Air Inlet
GA-11625	11,000	Lever Self Closing	5/8 - 11	4 1/2" & 5" Type 27	7 1/2"	4 lbs. 12 oz.	Steel	1/4 NPT
GA-11625A	11,000	Lever Self Closing	5/8 - 11	4 1/2" & 5" Type 27	7 1/2"	4 lbs.	Aluminum	1/4 NPT
GA-11650	11,000	Safety Lock Off	5/8 - 11	4 1/2" & 5" Type 27	7 1/2"	5 lbs.	Steel	1/4 NPT
GA-11650A	11,000	Safety Lock Off	5/8 - 11	4 1/2" & 5" Type 27	7 1/2"	4 lbs. 4 oz.	Aluminum	1/4 NPT
GA-11625-3/8	11,000	Lever Self Closing	3/8 - 24	4" Type 27	7 1/2"	4 lbs. 12 oz.	Steel	1/4 NPT
GA-11625A-3/8	11,000	Lever Self Closing	3/8 - 24	4" Type 27	7 1/2"	4 lbs.	Aluminum	1/4 NPT
GA-11650-3/8	11,000	Safety Lock Off	3/8 - 24	4" Type 27	7 1/2"	5 lbs.	Steel	1/4 NPT
GA-11650A-3/8	11,000	Safety Lock Off	3/8 - 24	4" Type 27	7 1/2"	4 lbs. 4 oz.	Aluminum	1/4 NPT

IMPORTANT: Never mount accessories that have lower maximum RPM rating than the tool, regardless of tool capacity. Never mount bonded grinding wheels. Always wear eye, face and body protection. Use only reinforced Type 27 wheels, 4" - 5" dia. x 1/4" wide max. x 3/8" center hole; wheels not included.

RIGHT ANGLE COLLET GRINDERS



APPLICATIONS

These tools are excellent for applications such as die contouring, deburring, blending and smoothing in hard-to-reach areas. They are used primarily with carbide burrs and mounted points. These tools are used in foundries, refineries, metal fab shops, power plants and other industries.

GA-1340-C SERIES

- Rugged 1 hp motor
- 13,500 rpm free speed
- Steel motor housing withstands heavy use
- Spiral beveled gears for longer life
- Side exhaust with adjustable deflector
- 1/2" side-to-center distance for easy accessibility to work-piece in tight areas
- Motor parts interchangeable with other 1340 /1350 tools
- Interchangeable with CP-3040-LABCID

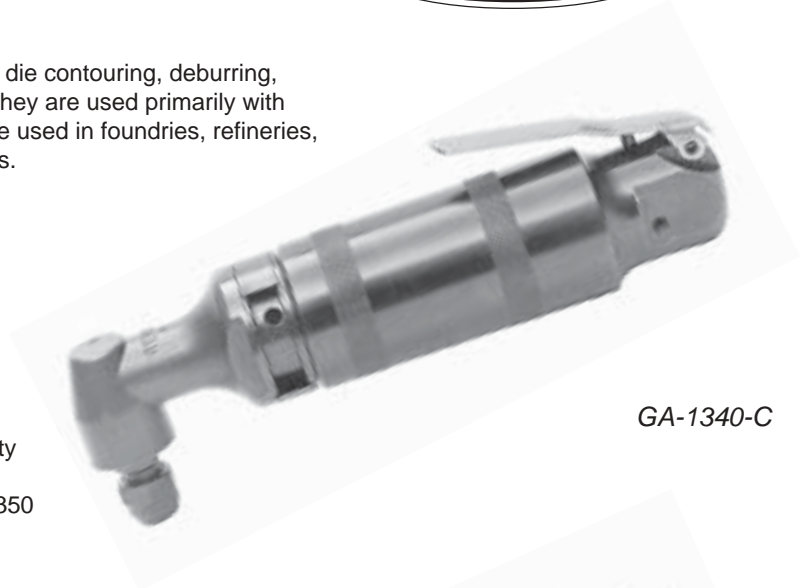

GA-1340-C

GA-1350-C SERIES

- Rugged 1 hp motor
- 13,500 rpm free speed
- Steel motor housing withstands heavy use
- Spiral beveled gears for longer life
- Side exhaust with adjustable deflector
- 1/2" side-to-center distance for easy accessibility to work-piece in tight areas
- Motor parts interchangeable with other 1340/1350 tools
- Safety Lever
- Interchangeable with CP-3040-GABCID



GA-1350-C

Now available in lightweight aluminum

GA-1340A-C SERIES

- Rugged 1 hp motor
- 13,500 rpm free speed
- Lightweight aluminum body
- Spiral beveled gears for longer life
- Side exhaust with adjustable deflector
- 1/2" side-to-center distance for easy accessibility to work-piece in tight areas
- Motor parts interchangeable with other 1340/1350 tools
- Interchangeable with CP-3040-LABCID



GA-1340A-C

STANDARD EQUIPMENT

- G-3327 Wrench
- G-3858 Wrench

OPTIONAL EQUIPMENT

- Safety Lever
- G-3781 Safety Lever on -1340 style housing

Patco Model No.	RPM	Throttle Type	Collet Size	Overall Length	Net Weight	Housing Type	Air Inlet
GA-1340-C	13,500	Lever Self Closing	1/4"	8"	2 lbs. 13 oz.	Steel	1/4 NPT
GA-1350-C	13,500	Safety Lock Off	1/4"	8"	3 lbs. 1 oz.	Steel	1/4 NPT
GA-1340A-C	13,500	Lever Self Closing	1/4"	8"	2 lbs. 2 oz.	Aluminum	1/4 NPT



EXTENDED RIGHT ANGLE WHEEL GRINDERS

GAL- EXTENDED RIGHT ANGLE SERIES TYPE 1 WHEEL GRINDERS

The very popular GAL-1340 and GAL-1350 style tool is now available in a Type 1 wheel design. The spindle has been lengthened to allow a Type 1 wheel with a maximum width of 1/4". For those hard-to-reach surfaces, when cutting or edge grinding is required, the GAL-Series Type 1 wheel grinders can meet the challenge. Industrial applications include foundries, welding shops, fabrication plants, steel mills and shipyards.

- Heavy duty 1 hp motor
- 15,500 free speed RPM
- Spiral bevel gears
- Available in steel or aluminum housing
- Side exhaust with adjustable deflector
- Small head for easy accessibility to tight work surfaces
- Interchangeable motor parts with all 1340/1350 series grinders

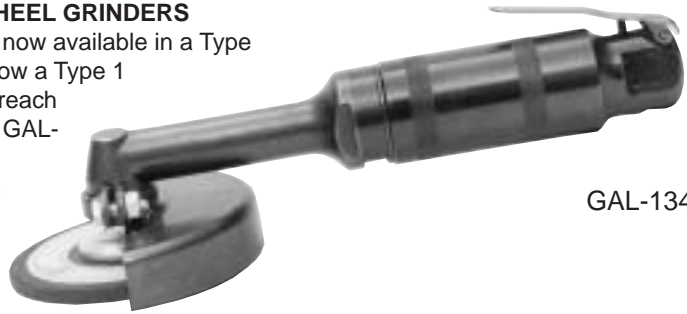

GAL-1340

GAL-1340 SERIES

- Extended reach keeps hands away from work
- 1/2" side-to-center distance for easy accessibility to work in tight areas



GAL-1350

Now available in lightweight aluminum

GAL-1350 SERIES

- Safety lever
- Extended reach keeps hands away from work
- 1/2" side-to-center distance for easy accessibility to work in tight areas

GAL-1340A SERIES

- Lightweight aluminum body
- Spiral bevel gears
- Extended reach keeps hands away from work
- 1/2" side-to-center distance for easy accessibility to work in tight areas

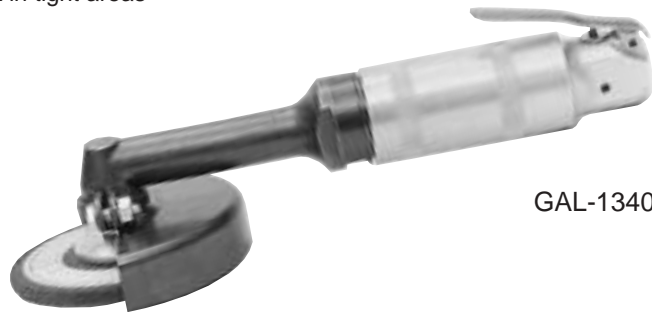

GAL-1340A

STANDARD EQUIPMENT

- GA-3500 4" Wheel guard
- GA-3652 Spanner Wrench
- GA-3653 Wrench
- G-3858 Wrench
- GA-3495 Type 27 Wheel Adapter
- GA-3588 Type 27 Wheel Nut

STANDARD EQUIPMENT

TYPE 1

- GA-3500 4" Wheel Guard
- GA-3495-1 Wheel Spindle Nut
- GA-3588-1 Wheel Nut
- GA-3652 Spanner Wrench
- GA-3653 Wrench
- G-3858 Wrench

OPTIONAL EQUIPMENT

- GA-3480 3" Wheel guard
- G-3781 Safety Lever on -1340 style housing

Patco Model No.	RPM	Throttle Type	Spindle Thread	Wheel Capacity	Overall Length	Net Weight Less Wheel	Housing Type	Air Inlet
GAL-1340	13,500	Lever Self Closing	3/8 - 24	3" and 4" Type 27	10"	3 lbs. 8 oz.	Steel	1/4 NPT
GAL-1350	13,500	Safety Lock Off	3/8 - 24	3" and 4" Type 27	10"	3 lbs. 12 oz.	Steel	1/4 NPT
GAL-1340A	13,500	Lever Self Closing	3/8 - 24	3" and 4" Type 27	10"	2 lbs. 13 oz.	Aluminum	1/4 NPT

Use only reinforced Type 27 wheel. 3" or 4" dia. x 1/4" wide max x 3/8" center hole; wheels not included.

Type 1 Wheel Extended Right Angle Grinder

GAL-1340-1	15,500	Lever Self Closing	3/8 - 24 1" Long	3" and 4" Type 27	10"	3 lbs. 4 oz.	Steel	1/4 NPT
GAL-1340A-1	15,500	Lever Self Closing	3/8 - 24 1" Long	3" and 4" Type 27	10"	2 lbs. 13 oz.	Aluminum	1/4 NPT
GAL-1350-1	15,500	Safety Lock Off	3/8 - 24 1" Long	3" and 4" Type 27	10"	3 lbs. 8 oz.	Steel	1/4 NPT
GAL-1350A-1	15,500	Safety Lock Off	3/8 - 24 1" Long	3" and 4" Type 27	10"	2 lbs. 12 oz.	Aluminum	1/4 NPT

IMPORTANT: Grinding wheel RPM must exceed tool RPM rating. Never mount bonded grinding wheels. Always wear eye, face and body protection. Use only reinforced Type 1 wheels, 3" or 4" dia. x 1/4" wide max x 3/8" center hole; wheels not included.

EXTENDED RIGHT ANGLE COLLET GRINDERS



APPLICATIONS

These grinders are used with mounted points and carbide burrs for a variety of applications such as die contouring and repair, weld cleaning, casting and forging clean-up, deburring, blending and smoothing. User industries include die shops, foundries, shipyards, construction, petrochemical and fabrication shops.

- Heavy duty 1 hp motor
- 13,500 RPM free speed
- Interchangeable motor parts with 1340/1350 tools
- Spiral bevel gears
- Adjustable side exhaust
- Extended reach for hard-to-reach areas
- 1/2" side-to-center distance for easy accessibility to work in tight areas



GAL-1340-C



GAL-1350-C

Now available in lightweight aluminum



GAL-1340A-C

GAL-1340-C SERIES

- Steel housing withstands heavy use
- Interchangeable with CP-3040-LASCID

GAL-1350-C SERIES

- Safety lever
- Interchangeable with CP-3040-GASCID

GAL-1340A-C

- Lightweight aluminum body
- Interchangeable with CP-3040-LASCID

STANDARD EQUIPMENT

- G-3327 Wrench
- G-3858 Wrench

OPTIONAL EQUIPMENT

- G-3781 Safety Lever on -1340 style housing

Patco Model No.	RPM	Throttle Type	Collet Size	Overall Length	Net Weight	Housing Type	Air Inlet
GAL-1340-C	13,500	Lever Self Closing	1/4"	10"	3 lbs. 3 oz.	Steel	1/4 NPT
GAL-1350-C	13,500	Safety Lock Off	1/4"	10"	3 lbs. 7 oz.	Steel	1/4 NPT
GAL-1340A-C	13,500	Lever Self Closing	1/4"	10"	2 lbs. 8 oz.	Aluminum	1/4 NPT

DOUBLE ANGLE COLLETS 200 DA Series

G-4158 Replaces:

- Aro #32968-5
- CP #C-119729Y
- Dotco #208
- Dresser #847811
- IR #G140-700-4
- Metal Remover #847811
- Rotor #1171-1317B
- Stanley #G-3027

G-3375 Replaces:

- Aro #32968-9
- CP #C-119730Y
- Dotco #212
- Dresser #847805
- IR #G140-700-6
- Metal Remover #847805
- Rotor #1171-1317D
- Stanley #G-3026

PART #	SIZE
G-4158	1/8"
G-4159	3/16"
G-3729	1/4"
G-3375	3/8"



COLLET CHUCK WRENCHES

These thin, high quality stamped wrenches are ideally suited for use with collet chucks. Close tolerance milled slots prevent damage to wrench flats on collet chuck bodies and nuts.

PART #	SIZE
G-3858	9/16"
GA-3652	Spanner
GA-3653	5/8"
G-3327	5/8" x 3/4"
GA-3864	1"



COLLET CHUCK ADAPTERS

The use of these adapters permits the use of various mounted wheels or burrs without changing collet chucks. Adapters are made with a shoulder to aid in removal with a minimum of inconvenience.

PART #	SIZE
G-4111	1/4" TO 1/8"

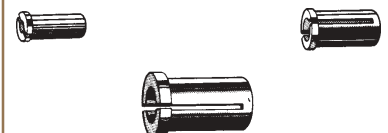



ROUTER & CUT-OFF WHEEL TOOL

APPLICATIONS: These routers are used for many applications such as cutting wood, trimming and cutting plastic parts, trimming flash from injection molded parts, window openings and various other uses.

- Powerful 1 H.P. motor
- Double angle collet for extreme accuracy
- Motor parts interchangeable with other 1340/1350 tools

Standard Equipment:

- G-3729 1/4" Collet
- G-3327 Wrench
- G-3858 Wrench

Optional Equipment:

- G-3781 Safety Lever on -1340 style housing
- Router Guide
- GR-2402, dimensions: A-1"; B-3/8"; C-3/8"; D-1/8"

Patco Model No.	RPM	Throttle Type	Overall Length	Net Weight	Housing Type
GR-2510	25,000	Lever Self Closing	6 3/4"	3 lbs. 4 oz.	Steel
GR-2510A	25,000	Lever Self Closing	6 3/4"	2 lbs. 8 oz.	Aluminum
GR-1810	18,000	Lever Self Closing	6 3/4"	3 lbs. 4 oz.	Steel
GR-1810A	18,000	Lever Self Closing	6 3/4"	2 lbs. 8 oz.	Aluminum



GR-1810 shown with aluminum housing

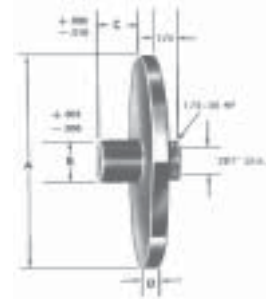

To determine minimum router bit length, add 2" plus "C" dimension, plus however long you would like the router bit to protrude.



G- CUT-OFF WHEEL TOOLS

The very popular G-1340 style tool is now available in a cut-off wheel design.

- Heavy duty 1 hp motor
- Available in steel or aluminum housing
- Interchangeable motor parts with all 1340/1350 series tools

Cut-Off Wheel Tools

Patco Model No.	RPM	Throttle Type	Spindle Thread	Wheel Capacity	Overall Length	Net Weight	Housing Type	Air Inlet
G-1340-1	25,000*	Lever Self Closing	3/8 - 24	3" & 4" Type 1	6 3/4"	2 lbs. 8 oz.	Steel	1/4 NPT
G-1340A-1	25,000*	Lever Self Closing	3/8 - 24	3" & 4" Type 1	6 3/4"	1 lbs. 12 oz.	Aluminum	1/4 NPT
G-1350-1	25,000*	Safety Lock Off	3/8 - 24	3" & 4" Type 1	6 3/4"	2 lbs. 12 oz.	Steel	1/4 NPT
G-1350A-1	25,000*	Safety Lock Off	3/8 - 24	3" & 4" Type 1	6 3/4"	2 lbs.	Aluminum	1/4 NPT

IMPORTANT: Grinding wheel RPM must exceed tool RPM rating. Never mount bonded grinding wheels. Always wear eye, face and body protection. Use only reinforced Type 1 wheels, 3" or 4" dia. x 1/32" - 1/8" wide max x 3/8" center hole; wheels not included.

AIR MARKING PENS



APPLICATIONS

These tools write on a variety of materials such as steel up to RC-64, glass, plastic and wood. They can be used for deburring, trimming and are excellent for removing broken studs.

PAS-361 SERIES

- Light weight, easy to operate
- Remove stylus and convert tool to chisel type scaler
- Stylus will write on materials up to RC-64
- Adjustable throttle for variety of jobs
- Hardened piston for long life
- Interchangeable with CP-9361

PAS-100 SERIES

- **Stylus-only head assembly** has the same great features as the PAS-361

STANDARD EQUIPMENT

- 7177 Stylus
- 7381 Air Filter Assembly
- 7886 Air Line
- 7999 Carrying Case

OPTIONAL EQUIPMENT

- 7425 Chisel Kit (PAS-361 only)



PAS-361



#7425 Chisel Kit

- 1/4" Flat Chisel
- Round Nose Chisel
- Chisel Blank
- Anvil
- 'O' rings

The PAS-361 will continue to provide an interchangeable head assembly. For use with the #7425 chisel kit.



PAS-100



Both models come with the Deluxe Carrying Case.

Designed for precision and durability, the PAS-100 offers a stylus-only head assembly.

Patco Model No.	Overall Length	Weight	Inlet	Hose I.D.	CFM
PAS-100	5"	5 OZ.	1/8 NPT	1/4"	1
PAS-361	5"	5 OZ.	1/8 NPT	1/4"	1



Our easy to use scalers feature a lever throttle with barrel and internal parts heat treated and precision ground.

P1-B SCALERS

These tools are excellent for removing weld splatter, rust, paint and other debris from many different and unusual surfaces and in hard-to-reach places. Construction, fabrication shops, refineries, foundries, and construction jobs will find these tools to be quite useful.

P1-B parts are interchangeable with CP-9356 and Cleco B1 style tools.

P1-B-L

This scaler has a replaceable tool nose and is available with needle attachment (see P-1-B-LN)



P1-B-L

P1-B-LN

This needle scaler has a round tube end removeable needle attachment which allows the tool to become a chisel scaler. 5" hardened alloy steel needles are standard. Optional 7" needles available.



P1-B-LN

P1-B-P

This scaler features a push-to-start handle, excellent for use in vertical positions and hard-to-reach areas. The P1-B-P is also available with the 9322-needle attachment. Order as a P1-B-PN.



P1-B-P

Optional Equipment for P1-B Series

- 9322 Needle Attachment (P1-B-L, P1-B-P)
- 9024 7" Needle (P1-B-LN, P1-B-PN)
- Uses #5342 thru #5351 chisels (see Chisel Accessories)

Patco Model No.	Blows Per Minute	Throttle Type	Piston Stroke	Overall Length	New Weight	Bore	Air Inlet
P1-B-L	4,600	Lever	1-1/8"	9 1/2"	4 lbs. 2 oz.	1"	3/8 NPT
P1-B-LN	4,600	Lever	1-1/8"	14"	6 lbs. 2 oz.	1"	3/8 NPT
P1-B-P	4,600	Push	1-1/8"	10 1/2"	6 lbs. 8 oz.	1"	1/4 NPT

AIR INLET BUSHING w/SCREEN

PART #	DESCRIPTION
9555	1/4" MPT X 1/4" FPT
P-1438	1/4" MPT X 3/8" FPT
9553	3/8" MPT X 1/4" FPT
P-3838	3/8" MPT X 3/8" FPT
P-3812	3/8" MPT X 1/2" FPT
P-1238	1/2" MPT X 3/8" FPT
P-1212	1/2" MPT X 1/2" FPT

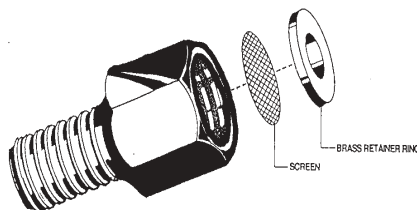

NEEDLES

PART #	DESCRIPTION
9043	5" x 1/8 (3mm)
9043-19	5" Needle Set 19 Needles
9024	7" x 1/8 (3mm)
9024-19	7" Needle Set 19 Needles

P-182 SERIES

These tools are excellent for removing weld splatter, rust, paint and other debris from many different and unusual surfaces and in hard-to-reach places. Construction, fabrication shops, refineries, foundries, and construction jobs will find these tools to be quite useful.

P-182 parts are interchangeable with IR-182 style tools.

P-182-L

Excellent for knocking sand from castings, trimming flash, chipping weld splatter cutting metal, removing paint and gaskets. Available with needle attachment (see P-182-LN).

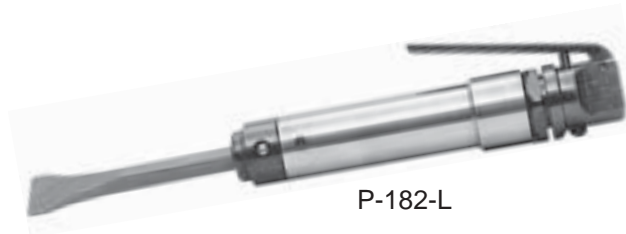

P-182-L



P-182-LN

P-182-LN

This scaler has a round tube end and removable needle attachment which allows tool to become a chisel scaler. Equipped with PNA11A5 needle attachment with hardened alloy steel 5" needles.

Patco Model No.	RPM	Throttle Type	Piston Stroke	Overall Length	Net Weight	Bore	Air Inlet
P-182-L	4,000	Lever	1-1/16"	9"	4 lbs. 2 oz.	15/16"	1/4 NPT
P-182-LN	4,000	Lever	1-1/16"	15"	6 lbs. 4 oz.	15/16"	1/4 NPT

P-182-P

This scaler features a push-to-start handle, excellent for use in vertical positions. Uses include knocking sand from casting, trimming flash and cutting metal.



P-182-P

P-182-PN

This needle scaler has a round tube end and a push-to-start handle. Excellent for removing paint and rust. Can easily be converted back to a standard scaler.



P-182-PN

Optional Equipment for P-182 and P-182-P

- Uses #5320 thru #5330 Chisels (see Chisel Accessories)
- PNA11A7 Needle Attachment with 7" needles

Patco Model No.	RPM	Throttle Type	Piston Stroke	Overall Length	Net Weight	Bore	Air Inlet
P-182-P	4,000	Push	1-1/16"	10-1/8"	3 lbs. 14 oz.	15/16"	1/4 NPT
P-182-PN	4,000	Push	1-1/16"	16-1/8"	6 lbs.	15/16"	1/4 NPT



SCALERS & RIVETING HAMMERS

456 SERIES

These tools will handle a variety of different scaling applications including knocking sand and ceramic from castings, removing weld splatter, paint, gaskets, etc. An excellent all-around maintenance tool.

456-L

Aggressive, heavy-duty scaler, 456 parts are interchangeable with CP-0456 style tools.

456-LN

Durable, heavy-duty scaler has a removable needle attachment which allows tool to become a chisel scaler. Equipped with #9043 5" hardened alloy steel needles. Optional 7" needles available.



456-L



456-LN

Patco Model No.	RPM	Throttle Type	Piston Stroke	Overall Length	Net Weight	Housing Type	Air Inlet
456-L	4,300	Lever	1"	8-5/8"	3 lbs. 1 oz.	15/16"	1/4 NPT
456-LN	4,300	Lever	1"	15-3/8"	5 lbs. 8 oz.	15/16"	1/4 NPT

Riveting Hammers



PATCO Model #	Rivet Capacity		Bore & Stroke	Blows per Minute	Overall Length
	Dural	Steel			
P-2X	1/8"	3/32"	1/2" x 2"	2580	6 11/16"
P-3X	3/16"	5/32"	1/2" x 2 7/8"	2160	7 5/16"
P-4X	1/4"	3/16"	1/2" x 3 7/8"	1740	8 5/16"
P-5X	1/4"	3/16"	3/4" x 2 11/16"	1560	8 15/16"
P-7X	3/8"	5/16"	3/4" x 5 13/16"	900	11 15/16"
P-9X	5/16"	1/4"	3/4" x 3 7/8"	1140	9 15/16"



RIVETING HAMMERS & WELD FLUX CHISELS



	DESCRIPTION	.401 Shank	.401Non Turn	.498 Shank	.498Non Turn
	Universal Joint & Tie Rod Tool	5101		5131	5141
	Tail Pipe Cutter	5102	5121		
	Fork Chisel	5103		5132	
	Fork Chisel	5104		5132	
	Bushing Remover Chisel	5105			
	Wide Chisel/Scraper 1 1/4" Blade	5106	5122	5133	5142
	Bushing Splitter	5107		5134	
	Claw Ripper-Edging Tool	5108	5123		
	Muffler Cutter	5109			
	Panel Cutter	5110	5124	5135	5144
	Panel Cutter (Non-Spark Material)	5111			
	Flat Chisel 3/4" Blade	5112	5125	5136	5144
	Flat Chisel 3/4" Blade-11" O.A.L.	5113	5126		
	Flat Chisel 3/4" Blade-18" O.A.L.	5114	5127	5137	5145
	Flat Chisel 1/2" Blade	5115			
	Flat Chisel 1 1/2" Blade	5116			
	Flat Chisel 2" (Non-Spark Material)	5117			
	Tapered Punch	5118	5128	5138	
	Rivet Cutter	5119	5129	5139	5146
	Straight Punch	5120	5130	5140	
	Weld Chisel-Spot Weld Breaker	5147			
	Piercing Punch #6	5148	5166		
	Piercing Punch #8	5149	5167		
	Piercing Punch #10	5150	5168		
	Spoon	5151	5169		
	Single Blade Cutter	5152	5170		
	Pencil Point	5153			
	Pencil Point 18" O.A.L.	5154			
	Muffler Cutter	5155			
	Kwik Cutter	5156			
	Inside Muffler Cutter	5157			
	Outside Muffler Cutter	5158			
	Moil Point	5159			5173
	Hammer 1" Diameter	5160		5172	
	Undercoat Scraper	5161			
	Nut Splitter 10" x 5/8"	5162			
	Nut Splitter 18" x 5/16"	5163			
	Nut Splitter 10" x 3/8"	5164			
	Nut Splitter 18" x 3/8"	5165			
	Diamond Point		5171		

Weld Flux Chisels

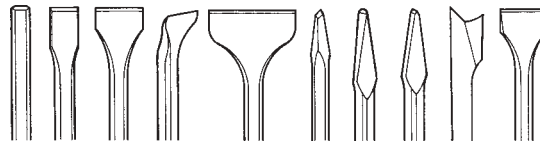

For Cleco, Rotor, Aro, CP #9356 and Patco #P1-B

DESCRIPTION	WIDTH	7" (178mm)	12" (305mm)	18" (457mm)
Blank		5342	5342-12	5342-18
Chisel	3/4" (19mm)	5343	5343-12	5343-18
Wide Chisel	1-3/8" (35mm)	5344	5344-12	5344-18
Angle Chisel	1-3/8" (35mm)	5345	5345-12	5345-18
Scraper	2" (50mm)	5346		
Scraper	3" (75mm)	5347		
Diamond Point	1/4" (6mm)	5348		
Round Nose	1/4" (6mm)	5349		
Cape Chisel	1/4" (6mm)	5350		
Panel Cutter		5351		

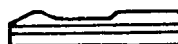

For Chicago Pneumatic-Keller Thor, Sioux-Aro Scalers-Ajax 1400Rockwell, I-R (172 & 182) Patco P-182 & Patco 456

DESCRIPTION	WIDTH	7" (178mm)	12" (305mm)	18" (457mm)
Blank		5320	5320-12	5320-18
Chisel	3/4" (19mm)	5321	5321-12	5321-18
Wide Chisel	1-3/8" (35mm)	5322	5322-12	5322-18
Angle Chisel	1-3/8" (35mm)	5323	5323-12	5323-18
Scraper	2" (50mm)	5324		
Scraper	3" (75mm)	5325		
Diamond Point	1/4" (6mm)	5326		
Round Nose	1/4" (6mm)	5327		
Cape Chisel	1/4" (6mm)	5328		
Panel Cutter		5329		
Heavy Blade Flat	1-1/4" (32mm)	5330	5330-12	

APPLICATIONS

These tools are used primarily with 3" and 4" sanding or polishing discs for many cleaning, deburring, blending and smoothing applications at shipyards, foundries, refineries, fabrication shops, power plants and a variety of other industries.

- Heavy duty 1 hp motor
- Steel Housing-durable
- Interchangeable motor parts with 1340/1350 tools
- Adjustable side exhaust-keeps work area clean
- Threaded male-type back-up pads
- 1/4 - 20 spindle
- RPM set between 6,000-15,500 to customer specification at the factory

GS-1340 SERIES

GS-1350 SERIES

- Safety lever

GS-1340A SERIES

- Lightweight aluminum body

STANDARD EQUIPMENT

- GS-1424 4" Back-up pad
- G-3858 Wrench

OPTIONAL EQUIPMENT

- Various back-up pads
- G-3781 Safety Lever on -1340 style housing



GS-1340-4



GSL-1340-4



GS-1350-4



GS-1340A-4



GSL-1350-4



GSL-1340A-4

Patco Model No.	RPM	Throttle Type	Spindle Thread	B/U Pad Capacity	Overall Length	Net Weight Less Wheel	Housing Type	Air Inlet
GS-1340-3	Per Customer	Lever Self Closing	1/4 - 20	3"	8"	3 lbs.	Steel	1/4 NPT
GS-1340-4				4"	8"	3 lbs.		
GSL-1340-3				3"	10"	3 lbs. 6 oz.		
GSL-1340-4				4"	10"	3 lbs. 6 oz.		
GS-1350-3	Per Customer	Safety Lock Off	1/4 - 20	3"	8"	3 lbs. 4 oz.	Steel	1/4 NPT
GS-1350-4				4"	8"	3 lbs. 4 oz.		
GSL-1350-3				3"	10"	3 lbs. 10 oz.		
GSL-1350-4				4"	10"	3 lbs. 10 oz.		
GS-1340A-3	Per Customer	Lever Self Closing	1/4 - 20	3"	8"	2 lbs. 5 oz.	Aluminum	1/4 NPT
GS-1340A-4				4"	8"	2 lbs. 5 oz.		
GSL-1340A-3				3"	10"	2 lbs. 11 oz.		
GSL-1340A-4				4"	10"	2 lbs. 11 oz.		



PATCO Air Tools, Inc. manufactures and develops durable, high quality industrial air tools and components for the metal working industry. In the past thirty years, our tools have earned an industry wide reputation for rugged, dependable performance.

PATCO tools are machined and assembled at our facility in Lapeer, Michigan. We maintain our standards of excellence by using only the finest materials and subjecting each tool to several stages of quality control. *PATCO* Air Tools will continue to work hard to manufacture a quality American-made tool and to serve our customers needs.

WARRANTY & TERMS

Warranty

Each *PATCO* air tool is guaranteed for 90 days from date of purchase to be free from defects in materials and workmanship. If you experience a defect with your *PATCO* air tool, simply return the tool, transportation prepaid, within the allotted time with your name, address, and dated proof of purchase, along with a brief explanation of the defect. This warranty does not apply to tools which have been abused, misused, modified or repaired by someone other than *PATCO* Air Tools, Inc. or one of its representatives. This warranty constitutes the entire obligation of *PATCO* Air Tools, Inc. relating to the sale of such product, and its maximum liability is limited to the purchase price of such product. In no event shall *PATCO* Air Tools, Inc. be liable for incidental, indirect, consequential or special damage of any kind arising from the sale or use of such product.

Merchandise Returns

All returns must receive prior approval from *PATCO* Air Tools, Inc. and display a Returned Merchandise Authorization number. All authorized returns will receive credit upon validation as new merchandise in saleable condition. No merchandise will be authorized for return if used, abused, or modified in any way, unless otherwise supported under the terms of warranty. All returns are subject to a 20% restocking fee.

Credit Terms

Upon credit approval, all new accounts are subject to credit terms of net 30 with no interest. Any accounts 31 days in arrears are subject to credit watch, and any accounts 45 days in arrears will be put on credit hold.

Minimum Orders

All orders are subject to a \$30.00 net minimum. No order will be invoiced for less than \$30.00.

PATCO Air Tools, Inc.
260 McCormick Drive, Lapeer, MI 48446
Phone (810) 667-6101 • Fax (810) 667-9489
www.patcoairtools.com • sales@patcoairtools.com



PATCO Air Tools, Inc.