

Breakdown

65VBW

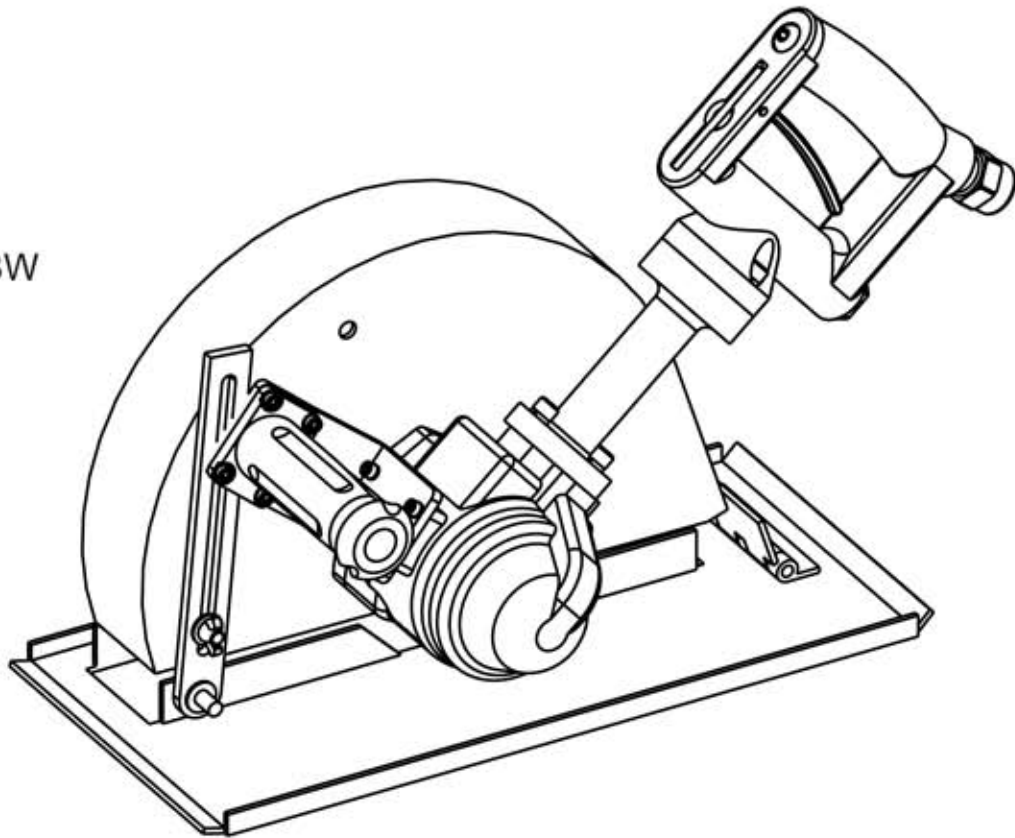

Top Cat ® Air Tools, Manufactured by T.C. Service Co.

Distributed by:
Just Tools Inc.
33A Haas Road, Toronto, On M9W 3A1
Tel: 416-748-0707 Toll Free: 1-888-748-0707
Fax: 416-748-0706 E-mail: sales@justools.com

65-VBW 9" GUARD

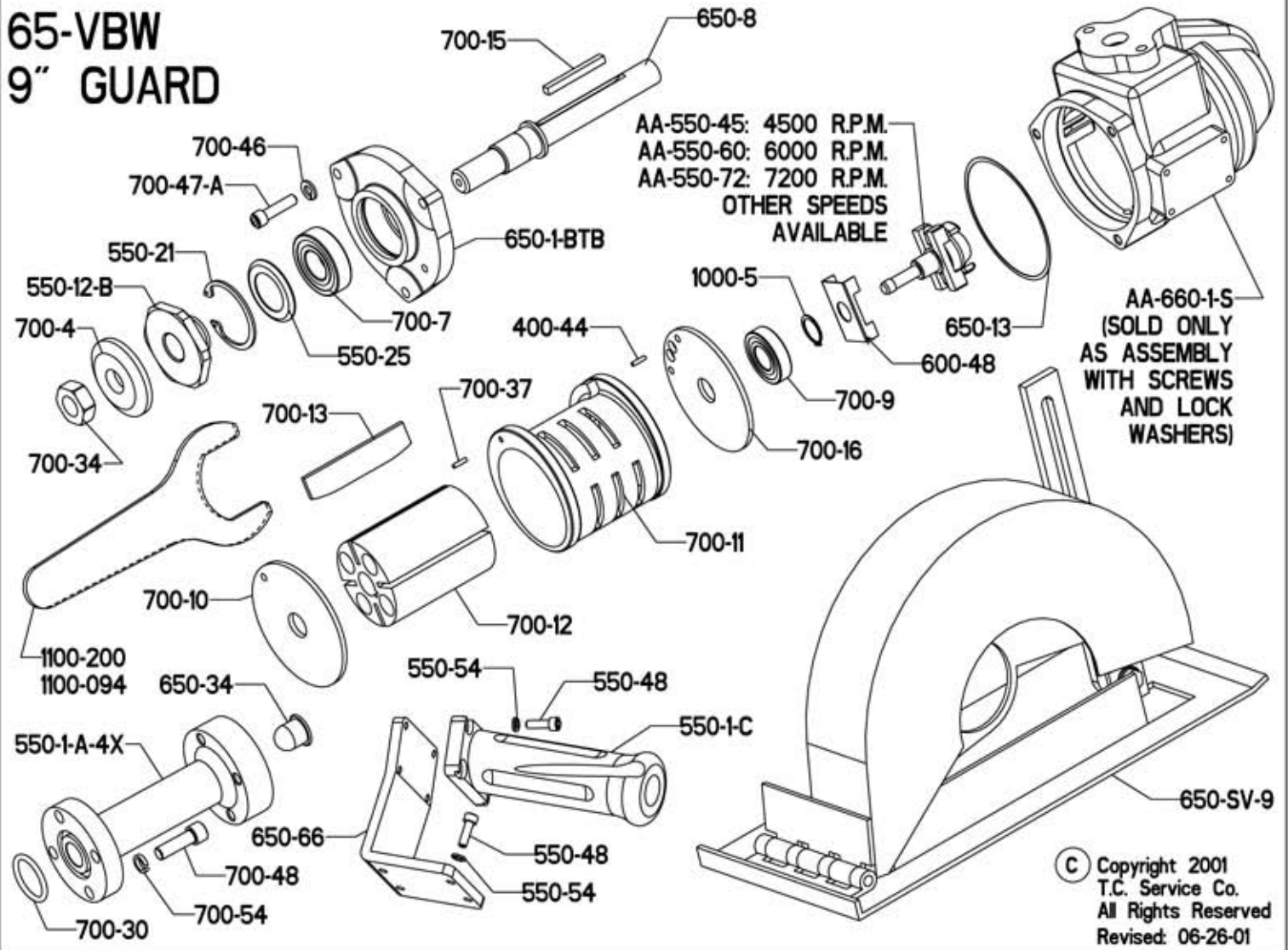

65-VBW 12" & 14" GUARD

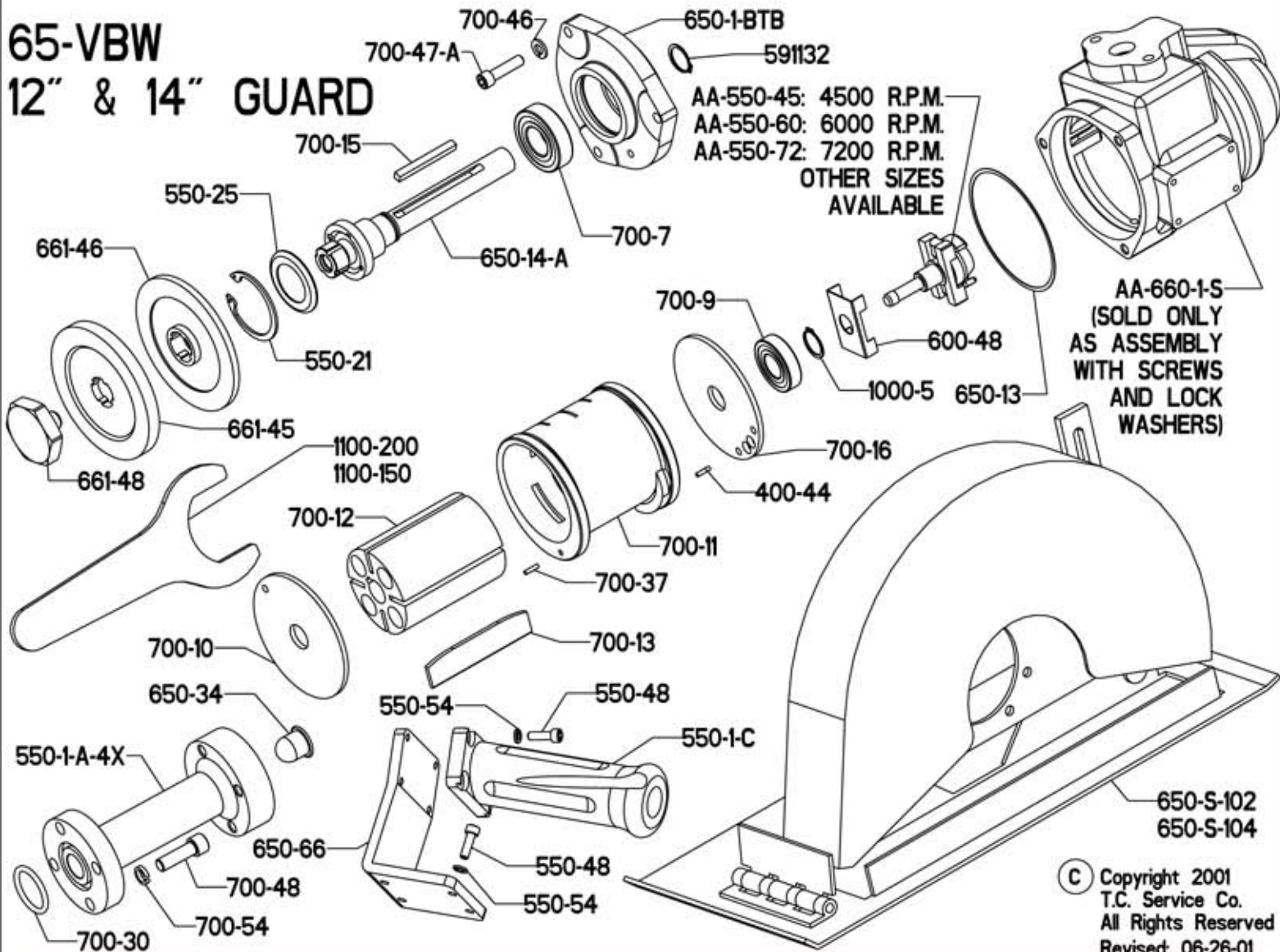

Handle Parts Listing

SPADE HANDLE PARTS

PART	DESCRIPTION
200-9	O-RING
550-H-3	BARE SPADE HANDLE
560-16	PLUG
560-19	THROTTLE VALVE ASSY. (INCLUDES 200-9)
600-52A	SPRING
600-55	PIN
700-23	SCREW
700-30	O-RING
700-48	SCREW (2 REQ.)
700-54	LOCK WASHER (2 REQ)
700-S-20	THROTTLE LEVER
700-S-26	THROTTLE VALVE CAP
832636	GASKET
841555	1/2"NPT X 1/2"NPT SCREEN
841555	HANDLE BUSHING
841555-M	1/2"NPT X 1/2"BSP SCREEN
841555-M	HANDLE BUSHING

Note: Use of any parts other than genuine Top Cat® parts voids any and all warranties, and may result in a hazardous situation and a decrease in operating efficiency.

Page 3 of 5

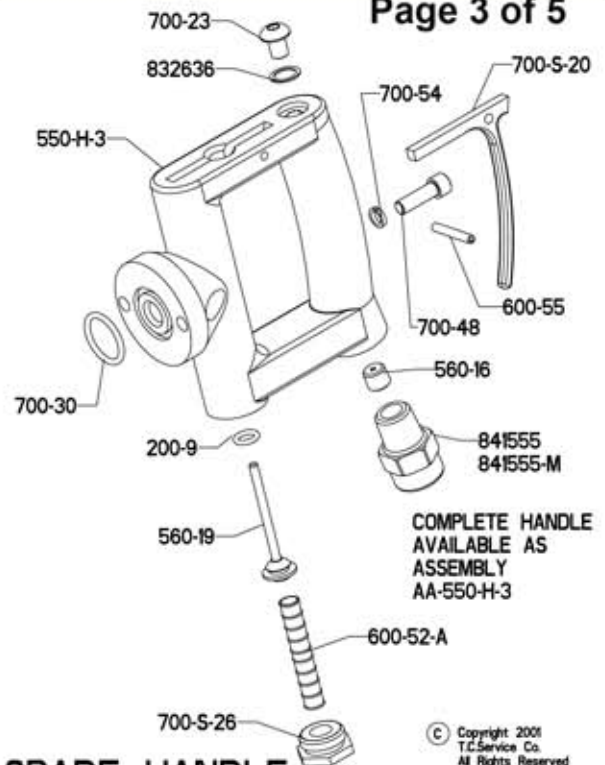

SPADE HANDLE

© Copyright 2001
T.C. Service Co.
All Rights Reserved
Revised: 06-26-01

Tool Parts Listing

<u>PART NUMBER</u>	<u>DESCRIPTION</u>
400-44	CYLINDER PIN
550-1-C	DEAD HANDLE
550-1-A-4W	WET CUT HANDLE EXTENSION
550-1-A-4X	HANDLE EXTENSION
550-1-C-KN	KNURLED DEAD HANDLE
550-1-C-KN-W	DEAD HANDLE WRAP
550-12B	WHEEL FLANGE
550-12B-LH	REV. ROT. WHEEL FLANGE
550-21	SNAP RING
550-25	BEARING COVER
550-48	SCREW (8 REQ)
550-54	WASHER (8 REQ)
650-S-1029	12" GUARD STOP
650-S-1049	14" GUARD STOP
650-SV-99	9" SLIDE STOP
650-1-BTB	BEARING SUPPORT
650-1-BTBS	STEEL FRONT BRG. SUPPORT
650-1-DB	DBL. BRG. FRONT SUPPORT
650-8	SPINDLE
650-8C	CHROME SPINDLE
650-8-DB	DOUBLE BEARING SPINDLE
650-8-LH	LH SPINDLE
650-8WL	WHEEL LOCK SPINDLE
650-13	GASKET
650-14-A	SPLINED SPINDLE
650-34	SCREEN BASKET
650-58	SCREW
650-59	WASHER
650-66	DEAD HANDLE BRACKET
661-45	3-1/2" OUTER WHEEL FLANGE
661-46	3-1/2" INNER WHEEL FLANGE
661-48	FLANGE NUT
661-52	5" OUTER WHEEL FLANGE
661-53	5" INNER WHEEL FLANGE
700-7	BEARING
700-9	BEARING
700-10	FRONT ENDPLATE
700-11	CYLINDER
700-11C	CHROME CYLINDER
700-11LH	LH CYLINDER
700-12	ROTOR
700-12A	ALUMINUM ROTOR
700-13	BLADES (4 REQ)
700-15	KEY
700-16	REAR ENDPLATE
700-30	O-RING
700-34	5/8-11 SPINDLE NUT
700-34-LH	LH 5/8-11 SPINDLE NUT
700-37	CYLINDER PIN
700-46	WASHER(3 REQ)
700-47A	SCREW (3 REQ)
700-48	SCREW (2 REQ)
700-54	LOCK WASHER (2 REQ)
1000-5	LOCK RING
591132	SNAP RING

GUARDS

<u>PART NUMBER</u>	<u>DESCRIPTION</u>
650-SV-9	9" SAW GUARD
650-S-102	12" SAW GUARD
650-S-104	14" SAW GUARD

TOOLS

<u>PART NUMBER</u>	<u>DESCRIPTION</u>
1100-94	15/16" WRENCH
1100-150	1-1/2" WRENCH
1100-200	2" WRENCH
1100-650	SPINDLE HOLDER
1100-808	700-9 BEARING DRIVER
1100-834	700-7 BEARING DRIVER
541228	2" X 12" LONG WRENCH

ASSEMBLIES

<u>PART NUMBER</u>	<u>DESCRIPTION</u>
510088	REPAIR KIT
AA-550-H-3	SPADE HANDLE ASSY
AA-660-1	CASE ASSY. (SPECIFY SPEED)
AA-660-1-PA	PIPED AWAY EXHAUST CASE ASSY. (SPECIFY SPEED)

ACCESSORIES

<u>PART NUMBER</u>	<u>DESCRIPTION</u>
AA-550-1-WGA	COMPLETE WET CUT ASSY.
550-1-A-4W	WET CUT HANDLE EXTENSION
550-1-A-8	WATER VALVE SET
550-1-A-14	6" LENGTH OF HOSE
550-1-A-16	1/8 ELBOW FITTING-WITH NUT
550-1-A-18	1/8 STRAIGHT FITTING-W/ NUT
550-1-A-18-B	NUT
550-1-A-20	BULKHEAD FITTING
550-1-A-22	HOSE ADAPTER FITTING
550-1-A-24	GASKET
550-1-A-26	10' LENGTH OF HOSE
550-1-A-28	PIPE FITTING
1100-690-VJ	WET FEED SHORT ADAPTER

GOVERNORS

<u>PART NUMBER</u>	<u>DESCRIPTION</u>
AA-550-40	GOV.ASSY. (4000 RPM)
AA-550-60	GOV.ASSY. (6000 RPM)
AA-550-60-LH	LH GOV. ASSY. (6000 RPM)

OTHER SPEEDS AVAILABLE. ALWAYS USE SAME OR LOWER SPEED GOVERNOR AS IS STAMPED ON CASE.

Governors

The governors are warranted for the life of the tool. (Except in cases of abuse) Please return the governor to the manufacturer for warranty repair or replacement.

